

9/16" HP Male  
1-1/8"-12UN Thread

1" Type M Male  
1"-12UN Thread

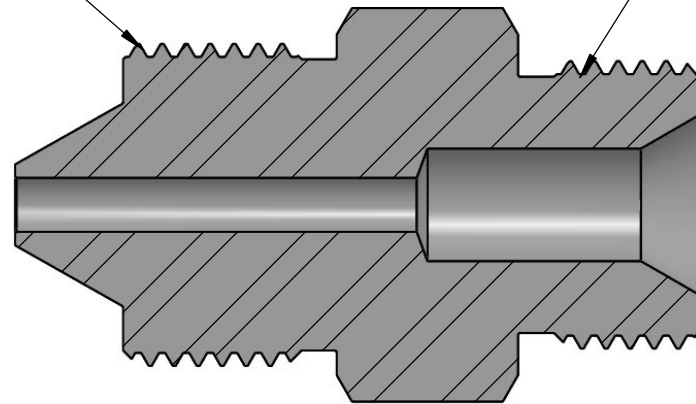

SECTION A-A

REVISION NOTES AND DATES

UNLESS OTHERWISE SPECIFIED:

- 1) DIMENSIONS ARE IN INCHES
- 2) TOLERANCES:  
 FRACTIONAL  $\pm 1/64"$   
 ANGULAR: MACH  $\pm 2^\circ$   
 ONE PLACE DECIMAL  $\pm .020$   
 TWO PLACE DECIMAL  $\pm .010$   
 THREE PLACE DECIMAL  $\pm .005$
- 3) THREADS UNIFIED CLASS  
 2A - 2B
- 4) SURFACE FINISH 63 $\mu$ in Ra
- 5) CHAMFER THREADS:  
 MALE -  $30^\circ$  TO ROOT  
 FEMALE -  $45^\circ$  TO ROOT

	NAME	DATE
DRAWN	MH	01/27/2026
CHECKED	KH	01/27/2026
DATE STARTED IN PRODUCTION:		
01/27/2026		

**ULTRA PRESSURE COMPONENTS  
HOUSTON, TX**

TITLE:  
9/16" HP Male x 1" Type M Male  
30,000 PSI

**PROPRIETARY AND CONFIDENTIAL**  
 THE INFORMATION CONTAINED IN THIS DRAWING IS THE SOLE PROPERTY OF ULTRA PRESSURE COMPONENTS. ANY REPRODUCTION IN PART OR AS A WHOLE WITHOUT THE WRITTEN PERMISSION OF ULTRA PRESSURE COMPONENTS IS PROHIBITED.



SIZE <b>A</b>	DWG. NO. <b>5404-9HM16</b>	REV <b>Y</b>
------------------	-------------------------------	-----------------

SCALE: 1.5:1    WEIGHT: 0.51    SHEET 1 OF 1